

Mobile Sensor Platform (MSP) v5.0

Zhifei Zhang, AICIP
Electrical Engineering and Computer Science, UTK
E-mail: zzhang61@vols.utk.edu

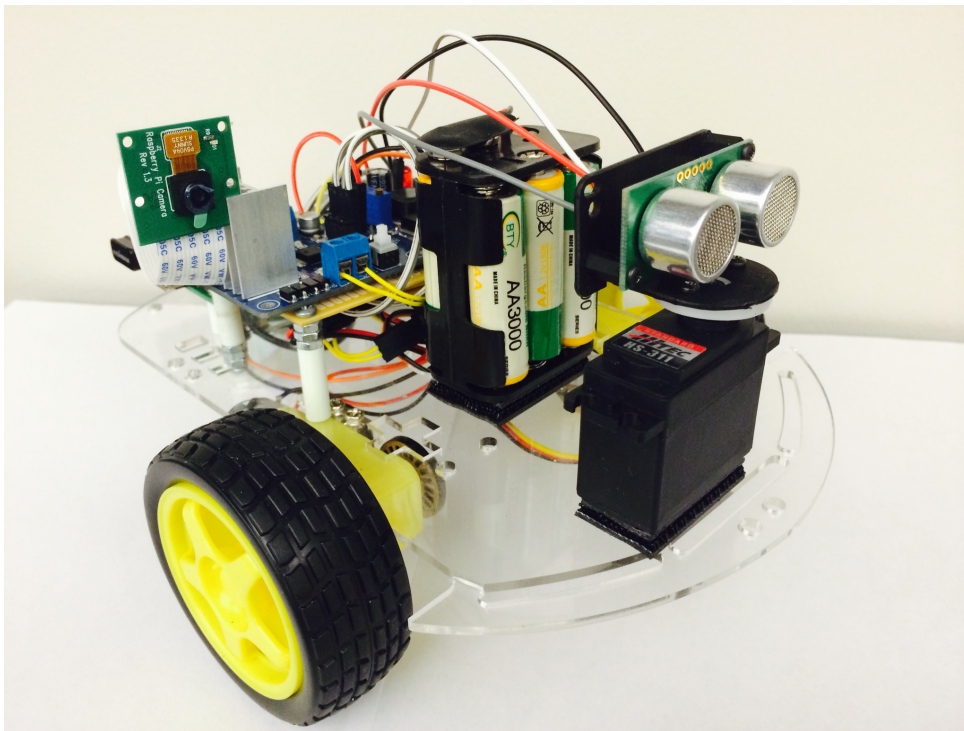

Date: 12/17/2014

Contents

1	Hardware	2
1.1	Motherboard: Raspberry Pi	2
1.2	Power: Adapter and Driver	2
1.3	Sensor: Camera and Sonar	3
1.4	Memory and WiFi	3
1.5	Car Model	3
2	Assembly Guide	4
2.1	Motherboard	4
2.2	Motor Driver	4
2.3	Sonar and Servo	4
3	Software	7
3.1	On-board Software	7
3.2	Sever Software	8
4	Appendix	9
4.1	Videos of Motion Test	9
4.2	Installation Recommendations	9
4.3	Part List	10

List of Figures

1	Hardware design	2
2	Raspberry Pi (Model B)	2
3	Power modules	3
4	Sensor modules	3
5	Memory and WiFi	3
6	Car model	4
7	The mobile sensor platform	4
8	Connection of motherboard	5
9	Connection of GPIO (denotations are listed in Table 1)	5
10	Connection of the driver module	6
11	Connection of the sonar module	6
12	Connection of the servo	6
13	Structure of on-board software modules	7
14	GUI of the server software	8

List of Tables

1	Meaning of denotations in Fig. 9	5
2	On-board software modules	7
3	Commands sent from the server	8
4	Part list of MSP v5.0	11

1 Hardware

Generally, design of hardware is shown in Fig. 1.

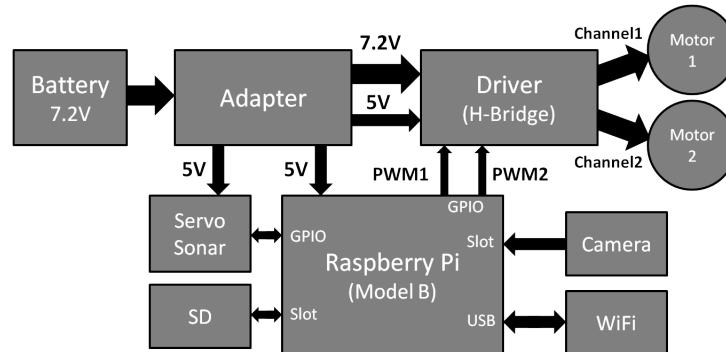

Figure 1: Hardware design

1.1 Motherboard: Raspberry Pi

Raspberry Pi (model B) is used as the motherboard, which is shown in Fig. 2.

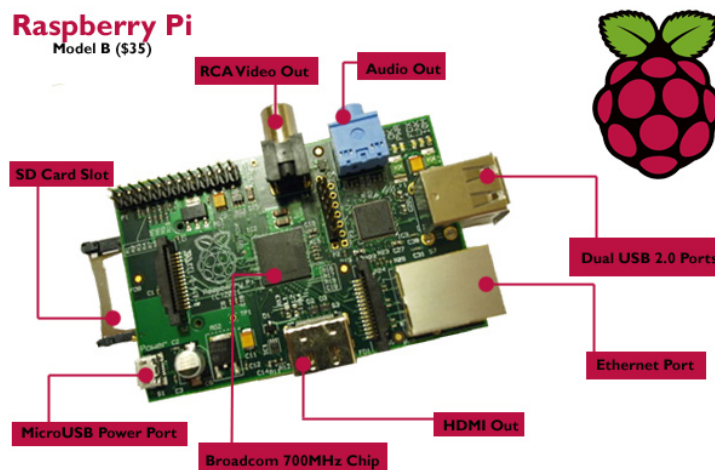
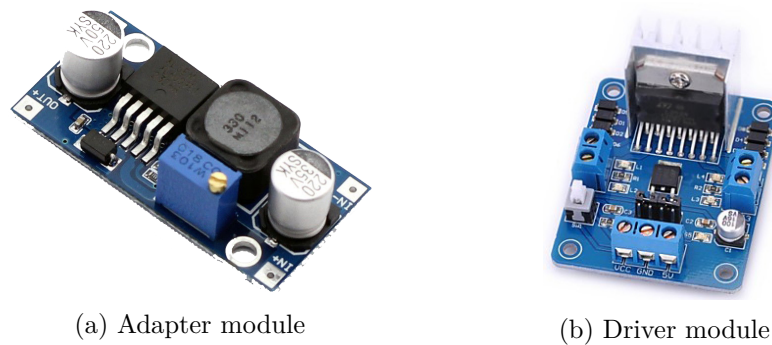

Figure 2: Raspberry Pi (Model B)

CAUTION: Never supply a voltage above 5.2V to Raspberry Pi.

1.2 Power: Adapter and Driver

Fig. 3 shows the adapter and driver modules. The adapter module converts 7.2V DC to 5V DC. Since the adapter module is adjustable through a variable resistance, the output should be calibrated to $5V \pm 0.2V$. The driver module mounted with L298N is supplied with 7.2V DC, and it can be controlled by PWM signal. Exactly, a pair of PWM signals control one motor, thus the motor can achieve two-way rotation.



(a) Adapter module

(b) Driver module

Figure 3: Power modules

1.3 Sensor: Camera and Sonar

Fig. 4 shows the camera and sonar modules, both of which need 5V DC power. Here, we use PiCam that is specifically designed for Raspberry Pi, and SRF05 sonar module is used to detect distance. Plenty of document related to these two modules can be found on line.

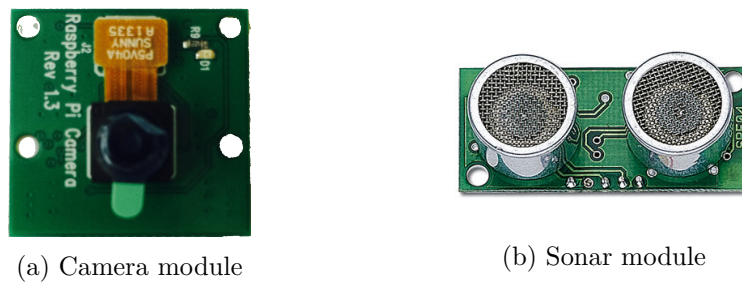

(a) Camera module

(b) Sonar module

Figure 4: Sensor modules

1.4 Memory and WiFi

Micro SD card and USB WiFi adapter are adopted, which are shown in Fig. 5.

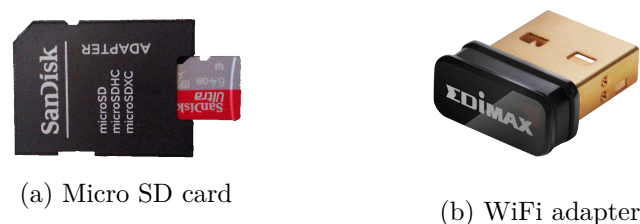

(a) Micro SD card

(b) WiFi adapter

Figure 5: Memory and WiFi

1.5 Car Model

The car model is shown in Fig. 6, which is much smaller than previous version. It consists of two motors, two wheels, an omni-wheel and a plastic holder. The motors are supplied by 5V DC and 120mA at most.

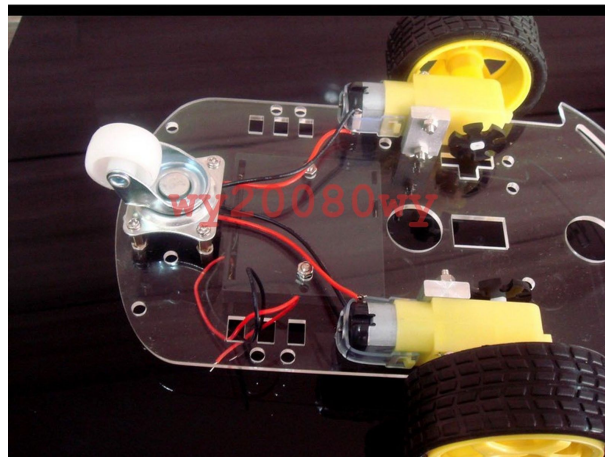

Figure 6: Car model

2 Assembly Guide

Assembling all parts, the mobile sensor platform is shown in Fig. 7.

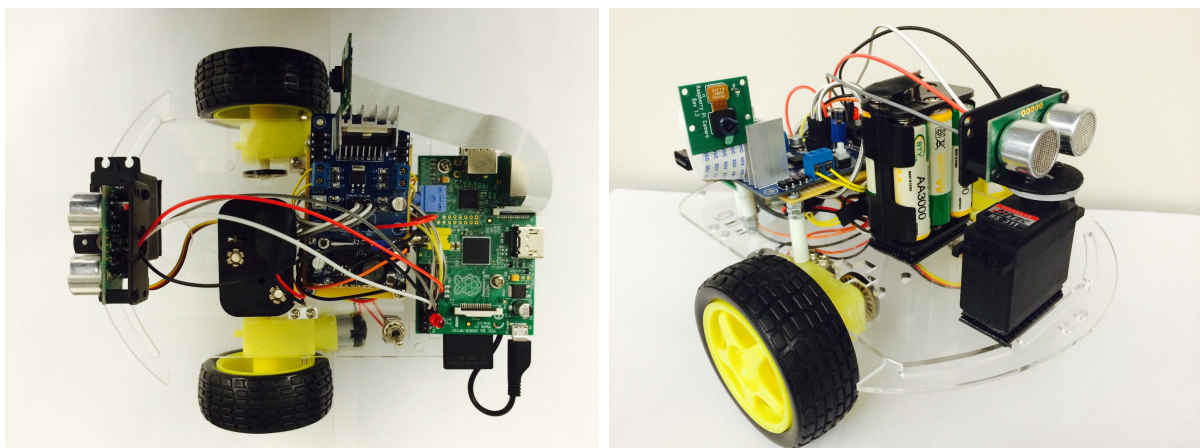

Figure 7: The mobile sensor platform

2.1 Motherboard

Fig. 8 shows the connection of motherboard. The detailed connection of GPIO is shown in Fig. 9, and the denotations are listed in Table 1.

2.2 Motor Driver

Connection of the driver module is shown in Fig. 10. The pin denoted as VCC on board connects to 7.2V.

2.3 Sonar and Servo

Connection of the sonar module is shown in Fig. 11. We only need to connect 4 lines: 5V—SN₊, 0V—SN₋, Echo—SN_E and Trigger—SN_T. Note that the voltage of SN₊

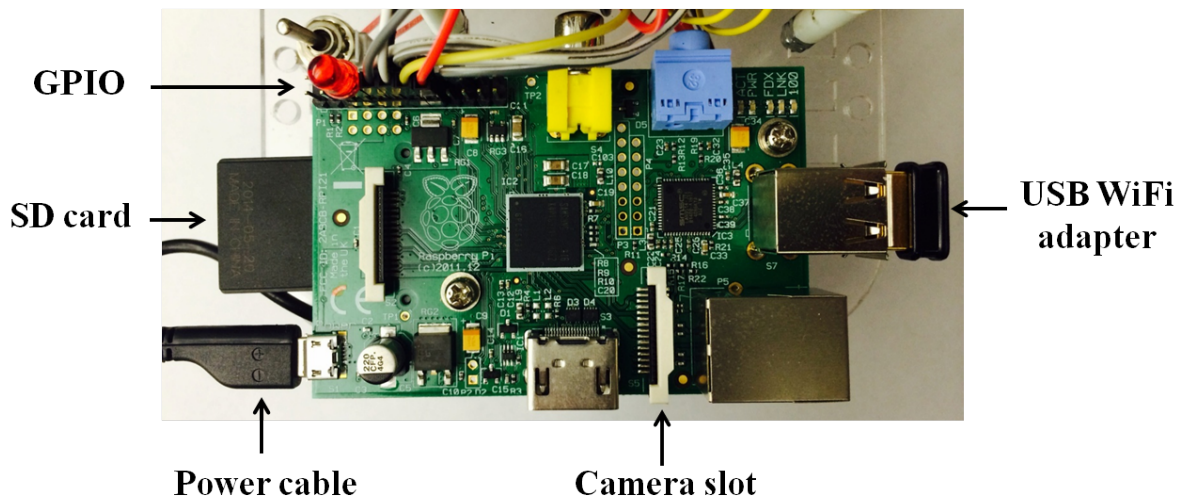

Figure 8: Connection of motherboard

Table 1: Meaning of denotations in Fig. 9

Denotation	Meaning
LM_n	the n th PWM signal for the left motor
RM_n	the n th PWM signal for the right motor
SV	PWM signal for the servo that controls the sonar
SN	connect to the sonar: power (+), ground (-), trigger (T) and echo (E)
L	connect to LED light: positive (+) and negative (-)

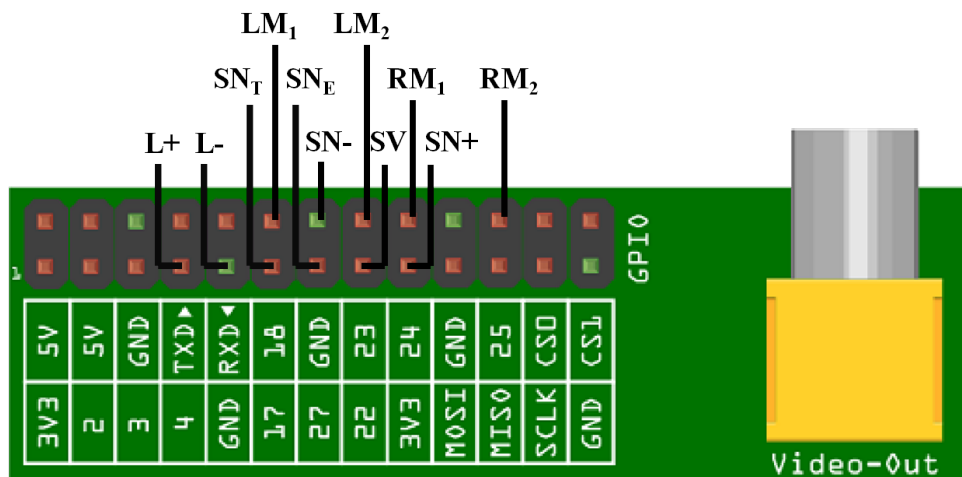

Figure 9: Connection of GPIO (denotations are listed in Table 1)

pin on Raspberry Pi is 3.3V that lower than required 5V. But it can still work normally in practice.

The servo is shown in Fig. 12.

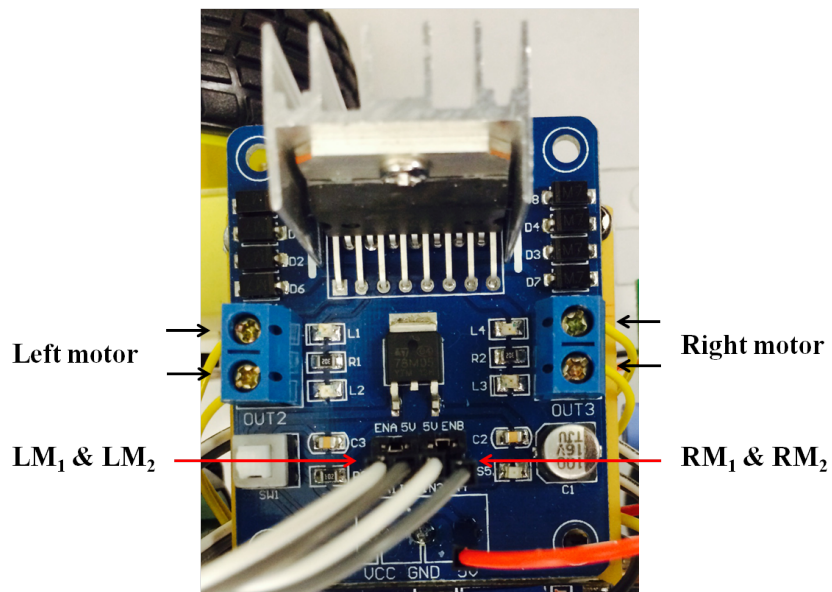

Figure 10: Connection of the driver module

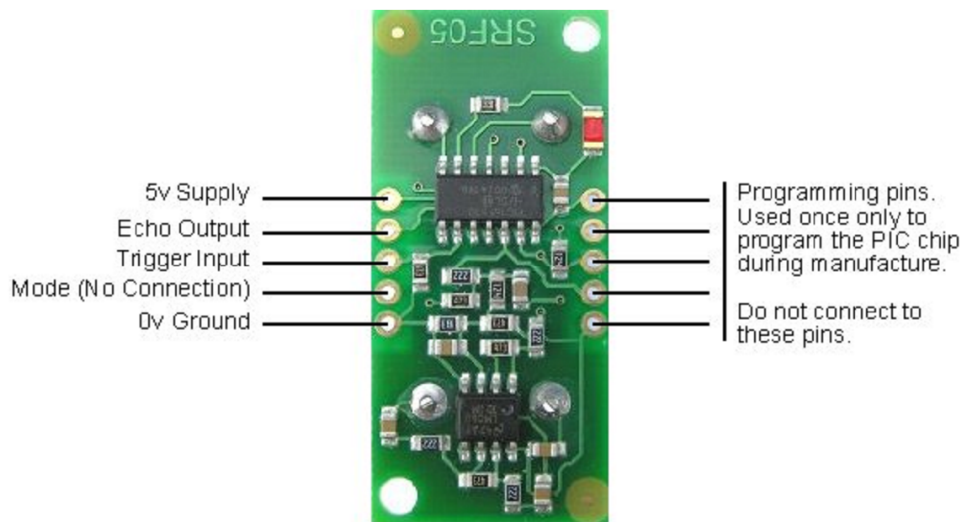

Figure 11: Connection of the sonar module

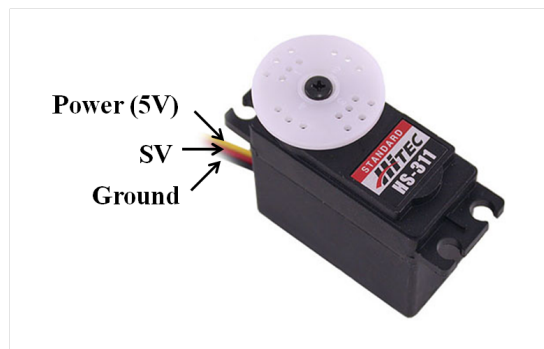

Figure 12: Connection of the servo

3 Software

A specially designed OS—Raspbian—is installed. Raspbian is a free operating system based on Debian optimized for the Raspberry Pi hardware. In addition, OpenCV (section 4.2.1) and its related package are also installed to support image processing work.

The on-board software can be divided into five parts: camera control module, GPIO control module, WiFi control module, image processing module and motion planning module. Currently, a mobile platform is designed as a terminal that can communicate with the server, which can communicate with multiple terminals (mobile platforms). Thus, all terminals can cooperate with each other indirectly through the server. Note that the sever can be a PC or MSP (section 4.2.2).

3.1 On-board Software

All on-board software modules are listed and described in Table 2. They are all written in Python 2.7.

Table 2: On-board software modules

Camera control module	Open and close the Pi camera module, control capture rate (frame/second)
GPIO control module	Initialize GPIO, set PWM and IO pins, modify PWM duty and IO state in order to control the motors, servo, sonar and LED
WiFi control module	Connect Raspbian Pi to the server via WiFi (UDP), do identification and communication
Image processing module	Embedded in the camera control module, process image for certain specific purpose
Motion planning module	Call all of above modules: <ol style="list-style-type: none"> 1. Collect feedback of all sensors and receive command from the server 2. Control the motors and servo according to collected information 3. Send current state to the server

Fig. 13 shows the structure of on-board software modules.

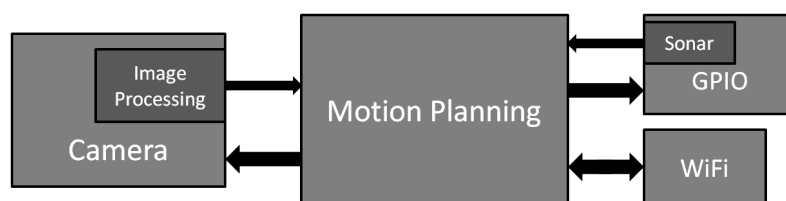

Figure 13: Structure of on-board software modules

3.2 Sever Software

The server software is written in Python 2.7, and it is only tested on the Windows 8 system. The GUI is shown in Fig. 14.

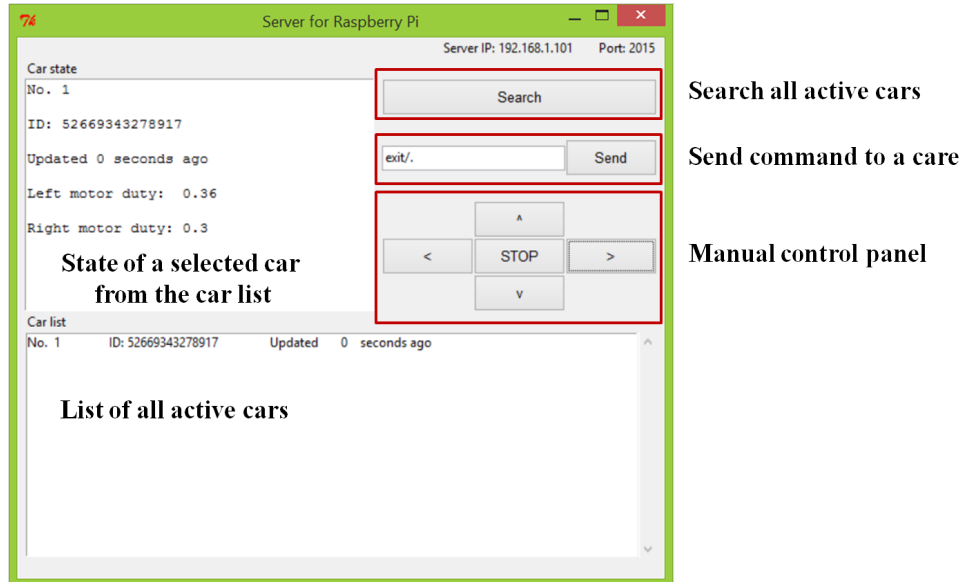

Figure 14: GUI of the server software

Currently, the software is still in the primary stage, the commands need to be sent from the server are listed in Table 3.

Table 3: Commands sent from the server

auto/.	Default mode, change to automatic mode, the manual control panel is locked
manu/.	Change to manual mode, the manual control panel is unlocked
sonar/ d	Under manual mode, control the sonar, d corresponds to rotation angle (degree)
n_L/n_R	Under manual mode, control the motors, n_L and n_R corresponds to rotation speed of the left and right motor respectively

4 Appendix

4.1 Videos of Motion Test

[Video1: Fixed motion test](#)

[Video2: Motion planning test using sonar](#)

More related works on MSP can be found from [AICIP Wiki](#)

4.2 Installation Recommendations

Installation instructions of OS, OpenCV, on-board and server software can be found from the [Dropbox](#), where also includes all Python code.

Hopefully, one can build a MSP by following these instructions even though s/he has no related experience. In order to well organize the whole installation procedure, we strongly suggest the following installation order:

1. Mount the PiCam and USB WiFi adapter to Raspberry Pi
2. Install OS to Raspberry Pi (need a HDMI monitor and a USB keyboard)
3. Access Raspberry Pi to Internet
4. Install OpenCV to Raspberry Pi
5. Install SSH to PC (make it easy to transform files between Raspberry Pi and PC)
6. Copy on-board software to Raspberry Pi, and copy server software to PC
7. Build the mobile platform
8. Connect Raspberry Pi and PC to the same LAN
9. Test the hardware and softwares

4.2.1 OpenCV

OpenCV (Open Source Computer Vision) is a library of programming functions mainly aimed at **real-time** computer vision. It is written in C++ and its primary interface is in C++, but there are now full interfaces in Python. After fully compiling, OpenCV (v2.4.9) will take about 500MB static storage space, which is not a problem for current storage devices. The SD card we used on MSP is 32GB.

Usually, only a little part of those library functions are used in a specific application. This makes OpenCV seems cumbersome, but this drawback can be overwhelmed by the optimized code for basic vision infrastructure and state-of-art algorithms. Canny edge detector, for example, one not expert in programming and computer vision can hardly beats OpenCV in running speed and performance. All algorithms in OpenCV is optimized and accelerated, they make the development fast without reinventing the wheel.

Above all, calling OpenCV functions can speed up your code, and it can automatically manage the memory. Here, we may ignore the static storage space that OpenCV takes since even a 8GB hard drive may be enough for installing an OS and OpenCV.

Raspberry Pi has a 512MB RAM (memory), and it can be mounted with a SD card with relatively large storage space. So, OpenCV is not a heavy burden for Raspberry Pi. Actually, the processing ability of CPU (700MHz ARM) is the shortest batten, so code optimization is imperative, which can be easily achieved using OpenCV.

4.2.2 Server

In general, any device with Python compiler and WiFi can be a server. So, a MSP itself can be a server because it runs a kind of Linux system with Python compiler and is mounted with a USB WiFi adapter. In another word, a MSP can be considered as a mobile PC. The only difference between the server and terminals is the program they are running. If a MSP runs the server program, then it is a server. Otherwise, it is a terminal.

Extremely, we can let all MSPs run both server and terminal programs, then everyone is a server and know current state of all the others. Whatever, all MSPs must be in the same LAN, so an access point (router) is always necessary.

4.3 Part List

The part list is shown in Table 4. Total price of the MSP v5.0 is about \$230.

Table 4: Part list of MSP v5.0

Component	Description	Price	Qty	Ship	Total
CAR MODEL	motors, wheels, plastic holder	14.88	1	0	14.88
MOTHERBOARD	Raspberry Pi 83-14421 Computer - Model B (512M RAM)	38.49	1	0	38.49
SENSOR	camera	50	1	0	50
	sonar	27.95	1	0	27.95
DRIVER	motor driver	3.2	1	0	3.2
	servo	7.99	1	0	7.99
COMMUNICATION	WiFi adapter	9.99	1	0	9.99
	Edimax 7811,usb adaptive,Supports 150 Mbps 802.11n				
POWER	battery	6.45	1	0	6.45
	battery charger	9.99	1	0	9.99
	Charger Smart Battery Charger for Rechargeable Batteries				
	battery holder	2.49	1	0	2.49
	PP3 connector	1.45	1	2	3.45
	battery snap on clip connector T Type Holder Lead Wire				
	voltage converter	1.95	1	0	1.95
	DC-DC Adjustable Step-up Power supply voltage Converter				
MEMORY	SD card	19.49	1	5	24.49
	SD card with adapter SanDisk -Ultra 32GB				
OTHERS	wire	7.64	1	0	7.64
	3 x 40P 20cm Dupont Wire Jumper Cable				
	PCB board	1.7	1	1.98	3.68
	DIY Prototype Paper PCB, 10Pcs 5 x 7 cm				
	GPIO extension board	4.18	1	1.98	6.16
	Raspberry Pi GPIO adapter board module for Raspberry Pi				
	LED	2.27	3	1.98	8.79
	green, red,yellow 5mm led light				
	screw & washer	0	0	0	0
	Hex Nut & Washer	0	0	0	0
	breadboard	0	0	0	0
					\$ 227.59